

**Table of Contents**

<b>Item</b>	<b>Description</b>	<b>Page</b>
1.	Introduction	2
2.	References	2
3.	Abbreviations	2
4.	<b>Technical</b>	
	4.1 Schematic	3
	4.2 Electrical specification	4
	4.3 HP-r Definition	5
	4.4 DC characteristic	5
	4.5 Test method	
	4.5.1 Insertion loss	6
	4.5.2 Return loss	7
5.	<b>Environmental</b>	
	5.1 Resistibility to over-voltage & over-currents	8
	5.2 Climatic conditions	
	5.2.1 Operating Temperature	8
	5.2.2 Storage and transport	8
	5.2.3 Operating humidity	8
6.	<b>Reliability</b>	
	6.1 Thermal shock	8
	6.2 Temperature and humidity exposure	8
	6.3 Vibration test	8
7.	<b>Mechanical</b>	
	7.1 Dimensions	9
	7.2 Rating plate	9

## 1. Introduction

The K2320ASH is a filter/splitter that has been specifically designed to implement the functionality of a low pass filter in POTS over ADSL application.

Asymmetric Digital Subscriber Line (ADSL) technology is a dedicated, point to point public network access technology that allow multiple forms of data, voice and video to be carried over twisted-pair copper wire on the local loop between a network service provider's (NSP'S) telephone exchange and the customer site or on local loops created either intra-building or intra-campus. ADSL delivers this high-speed performance over existing copper telephone line while simultaneously allowing a traditional analog service to coexist without interruption via a series of low-pass filters. The low-pass filter on the customer's premises is mounted inside a stand-alone ABS housing.

The K2320ASH integrates a low pass filter which blocks the ADSL high frequency signals from reaching the analog device and provides isolation from any impedance effects of the analog device on the ADSL transmission. The filter also attenuates any wideband impulse noise generated by the analog device due to the interruption of loop current (e.g. pulse-dialing or on hook / off hook conditions).

An unfiltered RJ11 socket is provided for connection of the ADSL modem.

Because the K2320ASH connects directly to the subscriber's loop media, it must also provide some surge protection from externally induced voltage which could damage any attached equipment or endanger humans interacting with the installed equipment. Additional surge protection measures are built into the K2320ASH to protect against line surges that could damage the filter itself.

## 2. Reference

Ref. 1 : ETS 300 001 Attachment to Public Switched Telephone Network

Ref. 2 : AS/ACIF S002 : 2001 Analogue inter-working and non-interference requirements for Customer Equipment for connection to the Public Switched Telephone Network

Ref. 3 : ITU-T K21 Resistibility of subscribers terminal to over-voltage and over-currents

## 3. Abbreviations

ADSL Asymmetric Digital Subscriber Line

CO Central Office

CPE Customer Premise Equipment

POTS Plain Old Telephone Service

RT Remote Terminal

ADSL-NT Network termination of ADSL

## 4. Technical

### 4.1. Schematic

The following drawing illustrates the block diagram of this product

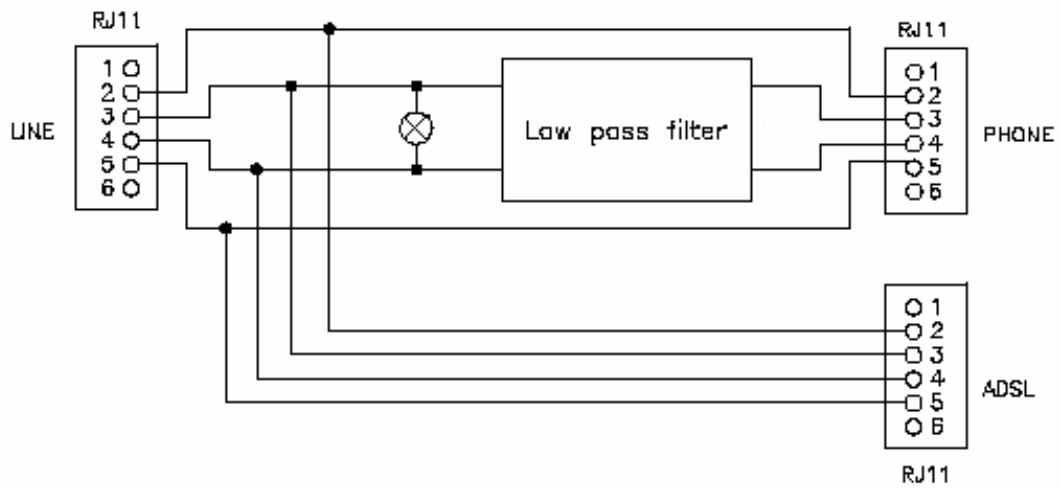

## 4.2. Electrical specification

The low pass filter shall satisfy the following parametric limits with a complex impedance ZL shown in this table across the Line side of this device

Splitter Parameters	Electrical requirements	
	Range	Values
<b>Frequency range</b>		
Nominal voice band		0.3KHz to 3.4KHz
Ringing frequency		22Hz ± 28HZ
ADSL band		30KHz to 1104KHz
Line Impedance ZL		220Ω + (820Ω    115nF)
CO Impedance ZTc		220Ω + (820Ω    115nF)
RT Impedance ZTr		220Ω + (820Ω    115nF)
Modem impedance	30KHz <f< 1104KHz	100Ω
<b>Operation voltage voice band</b>		
Normal signal		21mVpp to 5.4 Vpp
Billing tone		10Vpp to 30.2Vpp
Ringing signal		40Vrms to 80Vrms (113Vpp to 227Vpp)
DC voltage		0V to -72V
Max. AC voltage		70Vrms with -72VDC offset
Max. differential		190V
<b>Current voice band</b>		
Loop current		<120mA
Transient current (on/off hook)		<400mA
<b>DC resistance</b>		
DC resistance		<100Ω
Isolation tip/ring		>5MΩ
<b>Voice-band characteristics</b>		
Insertion loss for single splitter	1KHz	<1.5dB
	200Hz <f< 3.4KHz	<3.5dB
Insertion loss with 2 parallel filters	1KHz	<1.5dB
	200Hz <f< 3.4KHz	<3.5dB
Delay distortion	200Hz <f< 4KHz	<150u sec
Return loss for single splitter	300Hz <f< 2000Hz	>=15dB
	200Hz <f< 3.4KHz	>=12dB
Return loss for 2 parallel filters	300Hz <f< 2000Hz	>=15dB
	200Hz <f< 3.4KHz	>=12dB
Longitudinal conversion loss LCL	600Hz to 3.4KHz	>=45dB
<b>ADSL modem interface</b>		
Isolation Voltage		>2000Vrms for 1 minute
<b>ADSL band characteristics</b>		
Stop band attenuation (with ZHP-r)	30KHz	>18dB
	100KHz <f< 300KHz	>30dB
	300KHz <f< 1104KHz	>40dB
Stop band attenuation (without ZHP-r)	30KHz	>18dB
	100KHz <f< 300KHz	>30dB
	300KHz <f< 1104KHz	>40dB
Loading of ADSL signal path	300KHz <f< 1104KHz	<0.25dB

### 4.3. ZHP-r Definition

To facilitate the test of the splitter, the high pass data stream has to be considered. ZHP-r (shown below) is defined to allow proper termination of the ADSL port during voice band testing. ZHP-r is valid only for the voice band frequencies. ZHP-r is almost the same as  $27\text{nF} + 470\mu\text{H} // 100\Omega$  defined in AS/ACIF.

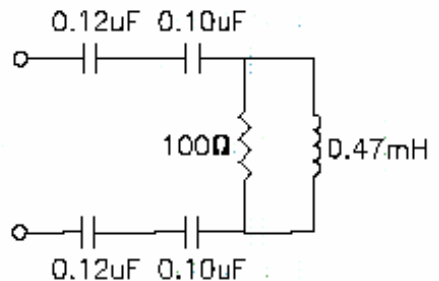

### 4.4. DC characteristic:

All requirements of this specification can be met in the presence of POTS loop currents from  $0\text{mA}$  to  $120\text{mA}$ .

This in-line filter can pass POTS tip-to-ring dc voltages of  $0\text{V}$  to  $72\text{V}$  and ringing signals of  $40\text{V}$  to  $80\text{V}$  rms at any frequency from  $15.3\text{Hz}$  to  $68\text{Hz}$  with a dc component in the range from  $0\text{V}$  to  $72\text{V}$ .

The dc resistance from tip-to-ring at the line port interface with the phone interface shorted, shall be less than or equal to  $100\text{ohms}$  for one filter. The DC resistance from tip-to-ground and from ring-to-ground at the POTS interface with the U-R interface open shall be greater than or equal to  $5\text{M}\Omega$ . The ground point shall be local building or green wire ground. The dc resistance should exceed  $10\text{M}\Omega$ .

## 4.5. Test method

### 4.5.1. Insertion loss

The insertion loss of a device connected into a given transmission system is defined as the ratio, expressed in dB, of the load power available (before and after insertion ) delivered to the output network beyond the point of insertion at a given frequency.

In general, the insertion loss of a device inserted in a given transmission system is mainly caused by internal component resistive loss with impedances between the source, the load and the device interfaces having been matched.

To perform the insertion loss measurement, through-calibration must be done prior to testing.

The insertion-loss equation can be expressed as:

$$\text{Insertion loss} = 20 \log \left| \left| \frac{V_2}{V_1} \right| \right| \text{ dB}$$

Where:  $V_1$  = the measured voltage value of load without LPF in circuit.  
 $V_2$  = the measured voltage value of load with LPF in circuit.

The test setup is shown in drawing below :

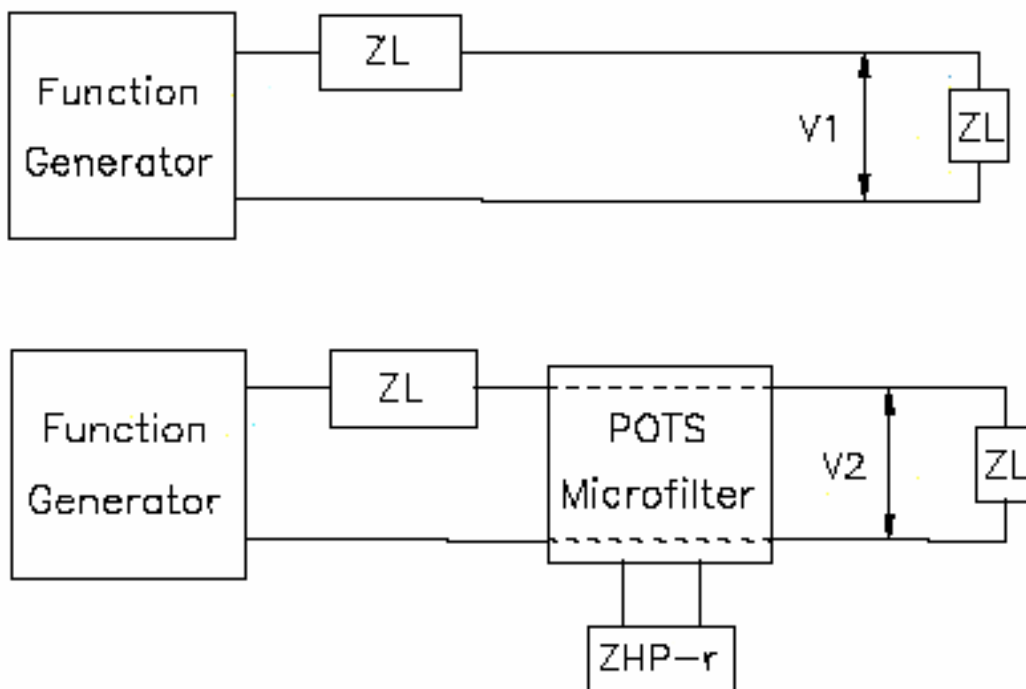

## 4.5.2. Return loss

Return loss measures the amount of lost energy due to reflection that is the result of any impedance mismatching at the interface. Return loss is essentially defined as the ratio of the power incident upon a given transmission system to the power reflected caused by impedance mismatch with respect to reference impedance at the interface between source and device.

The return-loss figure is a function of the impedance of the circuit involved and is therefore frequency dependent. These impedances must be closely maintained in order to reduce the possibility of undesirable reflection and echoes which occur in long distance circuits and effect the data being sent.

To perform the return loss test, open, short, load-calibration must be done prior measurement with the LCZ impedance analyser being in impedance mode.

Return loss is generally expressed in decibels. The return loss equation is:

$$\text{Return loss} = 20 \log \left| \frac{Z_L + Z_M}{Z_L - Z_M} \right| \text{ dB}$$

Where:  $Z_L$  = the reference impedance  
 $Z_M$  = the measured impedance

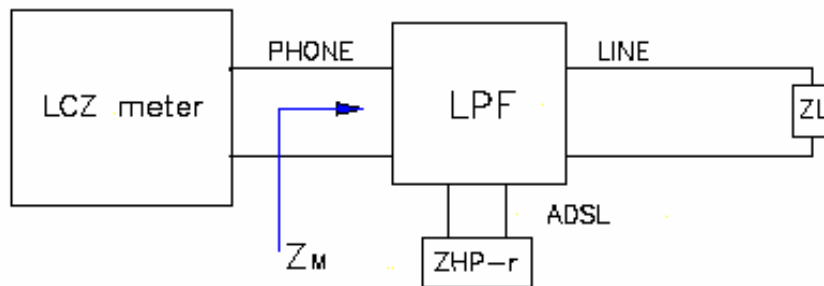

## **5. Environmental**

### **5.1. Resistibility to over-voltages and over-currents**

The splitter has to comply with requirements as per ITU-T K.21.

### **5.2. Climatic conditions**

#### **5.2.1. Operating temperature**

Application ..... indoor  
Long time operation guarantee temperature ( 5 to 40°C )  
Short time operation guarantee temperature ( 0 to 50°C )  
(According to ETS 300 019, class 3.2)

#### **5.2.2. Storage and transport**

Lowest ambient temperature - 20°C  
Highest ambient temperature +85°C  
(According to MIL-STD-202 method 107)

#### **5.2.3. Operation humidity**

Long time operation guarantee humidity ( 5 to 85 % )  
Short time operation guarantee humidity ( 5 to 90 % )  
Short time : within 72 continuous hours and 15 days in a year

## **6. Reliability**

### **6.1. Thermal shock**

Temperature from -20°C to +85°C for 5 cycles  
(According to MIL-STD-202, method 107)

### **6.2. Temperature humidity exposure**

+50°C /95RH, 96hrs  
(According to MIL-STD-202, method 103)

### **6.3. Vibration test**

Random vibration, frequency 5-500Hz, sweep time: 1 hr / axis /  
Force: 2.4grams  
(According to MIL-STD-202, method 204)

## 7. Mechanical

### 7.1 Dimensions

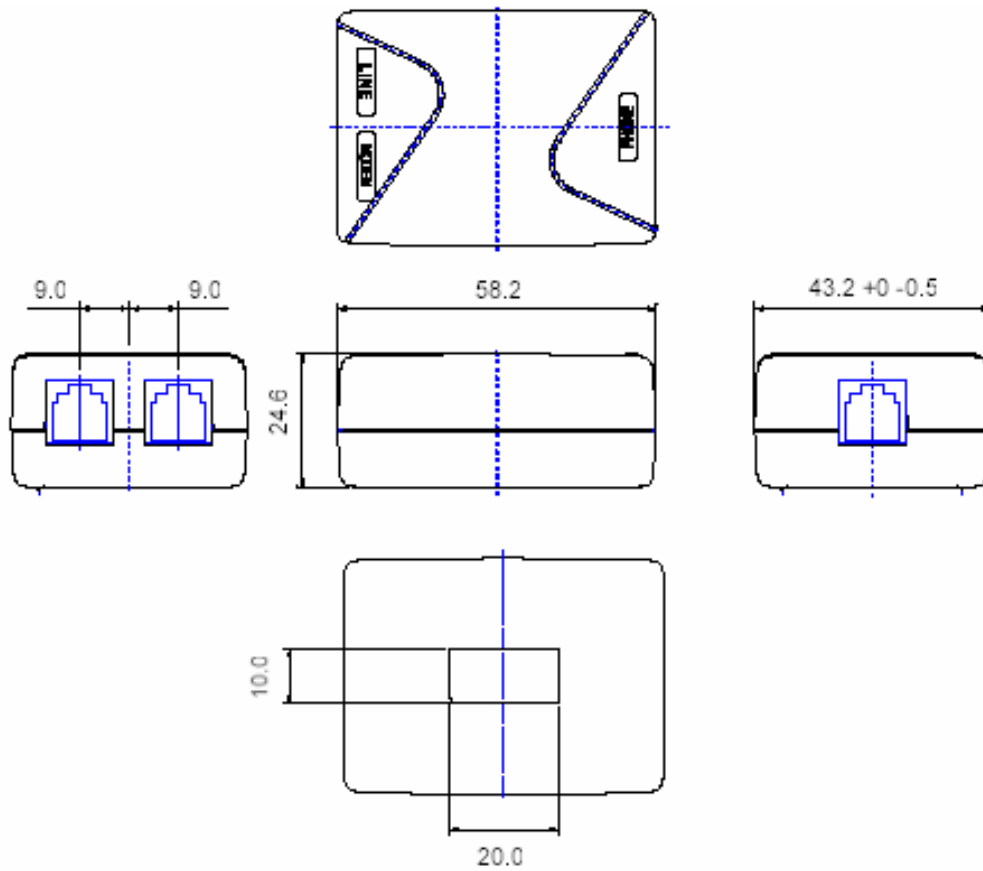

Note :1: Unless specified, all tolerances are  $\pm 0.25$ mm.

2: Color is Ash

### 7.2 Rating Plate

